

GRINDER



GIRANTE HCR
HIGH CHROME IMPELLER



TRITURATORE
CUTTING

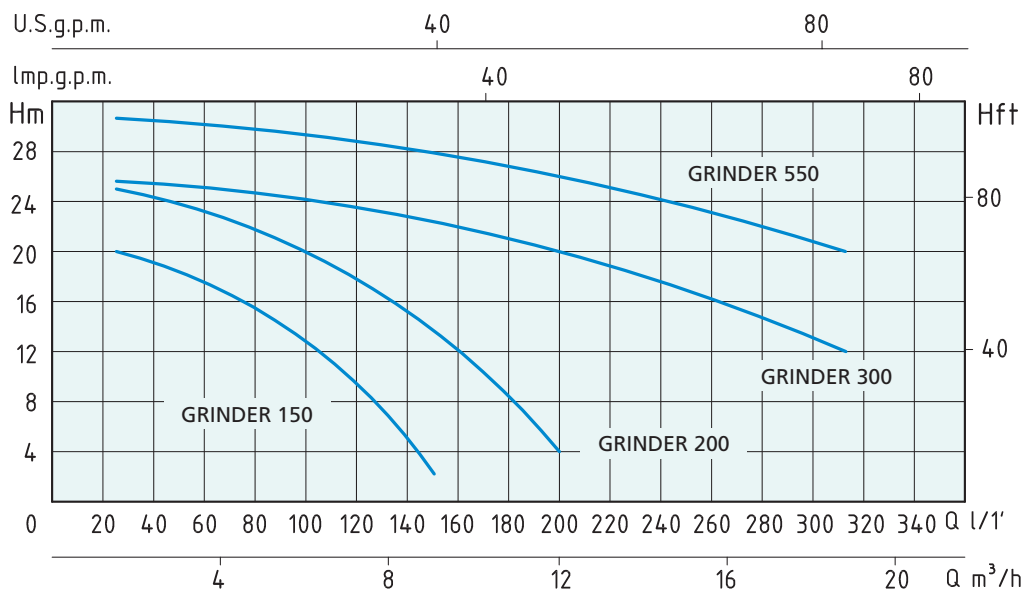

TIPO TYPE		POTENZA NOMINALE NOMINAL POWER		AMPERE		Q = PORTATA - CAPACITY												
						P2		Monofase Single-phase		Trifase Three-phase		m³/h						
Monofase Single-phase	Trifase Three-phase	HP	kW	Monofase Single-phase	Trifase Three-phase	lt/1'	1,5	3	6	8	9	12	15	16	18	19		
230V-50Hz	230/400V-50Hz			1 x 230V	3 x 400V		25	50	100	133,3	150	200	250	266,6	300	316,6		
GRINDER 150 S	GRINDER 150 T	1,5	1,1	7,5	3,2	H (m)	20	18,1	12,1	8	2							
GRINDER 200	GRINDER 200 T	2	1,5	8,5	3,5		24,9	23,8	20,3	13	10	4						
GRINDER 200 S		2	1,5	8,5	3,5		24,9	23,8	20,3	13	10	4						
	GRINDER 300-T	3	2,2		5,5		25,2	25,1	24,4	23,3	22,5	20	16	15	13	12		
	GRINDER 550-T	5,5	4		12,2		31,3	31,2	30,4	29,1	28,4	26	24	23	21	20		

Prevalenza manometrica totale in m.C.A. - Total head in meters w.c.

ELETTROPOMPE SOMMERSE CON TRITURATORE CUTTING SUBMERSIBLE PUMPS

WORTEX

APPLICAZIONI

Elettropompa con girante immersa di tipo multicanale aperta con sistema di triturazione in aspirazione.

Particolarmente indicata in presenza di lunghe fibre filamentose o fibrose, di corpi solidi distruttibili anche di grandi dimensioni, nel trattamento di liquidi biologici e di acque di origine civile.

LIMITI D'IMPIEGO

- Temperatura liquido fino a 35°C (per un uso domestico secondo EN 60335-2-41)
Temperatura max. liquido: 40°C (per altri impieghi)
- Massima profondità d'immersione 30 mt. (con cavo di adatta lunghezza)
- Livello min. d'aspirazione 160 mm
- Servizio continuo

MOTORE

- Isolamento Classe F
- Protezione IP 68
- Protettore termico
- Funzionamento a secco

MATERIALI

- Corpo motore Ghisa
- Corpo pompa Ghisa
- Girante Ghisa
- Albero motore Acciaio Inox AISI 304
- Trituratore Acciaio Inox AISI 304
- Doppia tenuta meccanica in camera d'olio Ceramica/Grafite/NBR
Silicio/Silicio/NBR

APPLICATION

Electric pump with plunged impeller, this impeller is multi-pipe, open, with a cutting system in the suction.

It is particularly suitable in presence of long, filamentous or fibrous fibres, of destroyable solids also of big dimensions and in biologic liquids or in civil waters.

OPERATING CONDITIONS

- Liquid temperature up to 35°C (for home use according to EN 60335-2-41)
Temperature max. liquid: 40°C (for other uses)
- Maximum immersion depth 30 mt. (with a cable of the appropriate length)
- Min. suction level 160 mm
- Continuous duty

MOTOR

- Insulation Class F
- Protection IP 68
- Thermic protection
- Dry type

MATERIALS

- Motor body Cast Iron
- Pump body Cast Iron
- Impeller Cast Iron
- Shaft with rotor Stainless Steel AISI 304
- Cutting Stainless Steel AISI 304
- Double mechanical seal in oil chamber Ceramic/Graphite/NBR
Silicon/Silicon/NBR

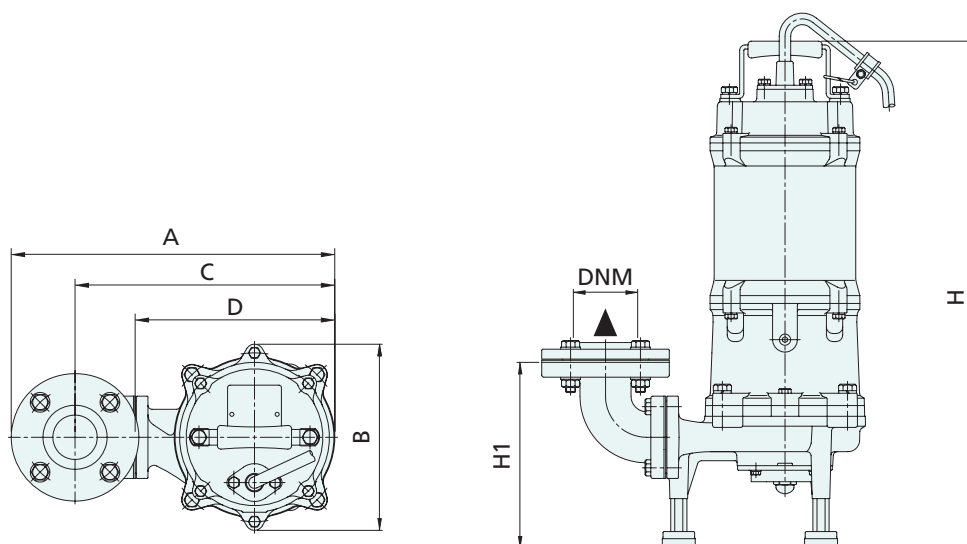

TIPO TYPE		DIMENSIONI mm - DIMENSIONS mm							DIMENSIONI DIMENSIONS mm			PESO WEIGHT Kg	
Monofase Single-phase	Trifase Three-phase	A	B	C	D	H	H1	DNM	CAVO CABLE	P	L		H
GRINDER 150 S	GRINDER 150 T	249	177	214	-	555	156	1"¼	10 mt H07RNF	270	260	540	31
GRINDER 200	GRINDER 200 T	285	203	250	-	597	156	1"¼	10 mt H07RNF	270	260	680	38
GRINDER 200 S		285	203	250	-	597	156	1"¼	10 mt H07RNF	270	260	680	38
	GRINDER 300-T	393	226	316	243	616	226	2"	10 mt H07RNF	410	430	810	56
	GRINDER 550-T	393	226	316	243	616	226	2"	10 mt H07RNF	410	430	810	62